

NE5532, NE5532A DUAL LOW-NOISE OPERATIONAL AMPLIFIERS

SLOS075G – NOVEMBER 1979 – REVISED JUNE 2002

- **Equivalent Input Noise Voltage**
5 nV/ $\sqrt{\text{Hz}}$ Typ at 1 kHz
- **Unity-Gain Bandwidth . . . 10 MHz Typ**
- **Common-Mode Rejection Ratio . . . 100 dB Typ**
- **High dc Voltage Gain . . . 100 V/mV Typ**
- **Peak-to-Peak Output Voltage Swing 32 V Typ** With $V_{CC\pm} = \pm 18 \text{ V}$ and $R_L = 600 \Omega$
- **High Slew Rate . . . 9 V/ μs Typ**
- **Wide Supply-Voltage Range . . . $\pm 3 \text{ V}$ to $\pm 20 \text{ V}$**
- **Designed to Be Interchangeable With**
Signetics NE5532 and NE5532A

D, P, OR PS PACKAGE
(TOP VIEW)

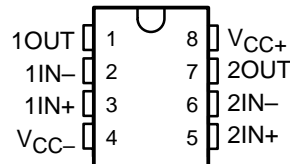

description/ordering information

The NE5532 and NE5532A are high-performance operational amplifiers combining excellent dc and ac characteristics. They feature very low noise, high output-drive capability, high unity-gain and maximum-output-swing bandwidths, low distortion, high slew rate, input-protection diodes, and output short-circuit protection. These operational amplifiers are compensated internally for unity-gain operation. The NE5532A has specified maximum limits for equivalent input noise voltage.

ORDERING INFORMATION

T _A	PACKAGE†		ORDERABLE PART NUMBER	TOP-SIDE MARKING	
0°C to 70°C	PDIP – P	Tube	NE5532P	NE5532P	
			NE5532AP	NE5532AP	
	SOIC – D	Tube	NE5532D	N5532	
			Tape and reel		NE5532DR
			Tape and reel	NE5532AD	N5532A
				NE5532ADR	
	SOP – PS	Tape and reel	NE5532PSR	N5532	
			NE5532APSR	N5532A	

† Package drawings, standard packing quantities, thermal data, symbolization, and PCB design guidelines are available at www.ti.com/sc/package.



Please be aware that an important notice concerning availability, standard warranty, and use in critical applications of Texas Instruments semiconductor products and disclaimers thereto appears at the end of this data sheet.

PRODUCTION DATA information is current as of publication date. Products conform to specifications per the terms of Texas Instruments standard warranty. Production processing does not necessarily include testing of all parameters.

**TEXAS
INSTRUMENTS**

POST OFFICE BOX 655303 • DALLAS, TEXAS 75265

Copyright © 2002, Texas Instruments Incorporated

NE5532, NE5532A DUAL LOW-NOISE OPERATIONAL AMPLIFIERS

SLOS075G – NOVEMBER 1979 – REVISED JUNE 2002

schematic (each amplifier)

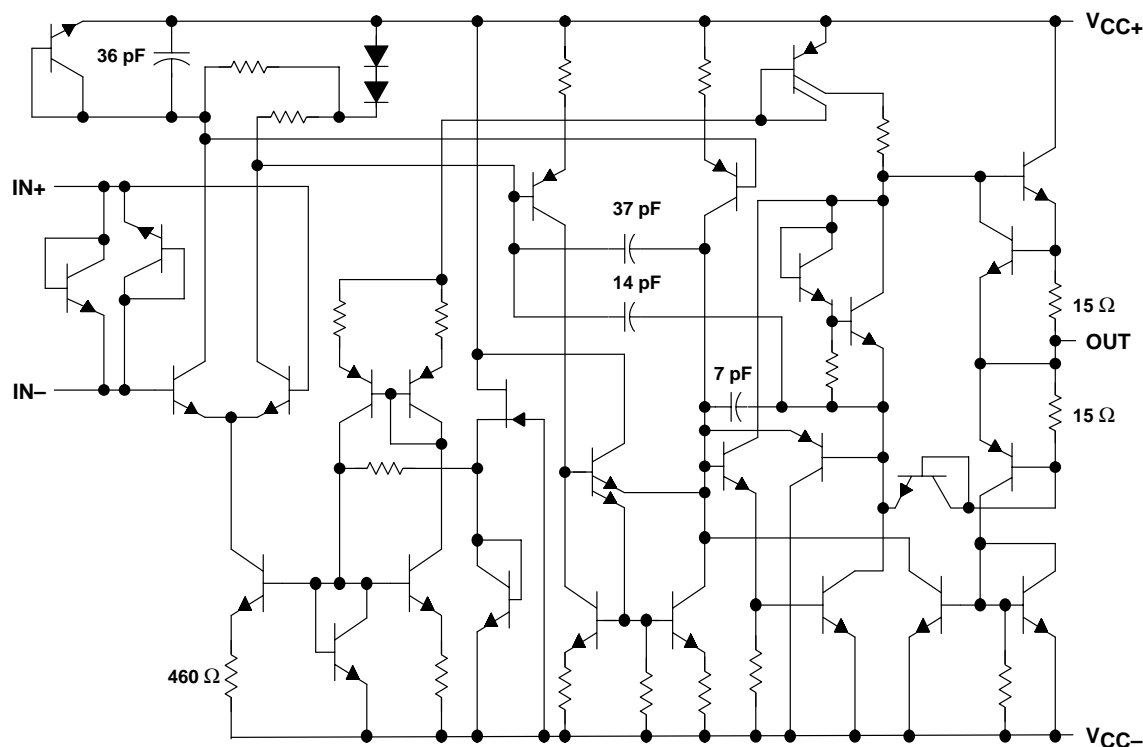

Component values shown are nominal.

absolute maximum ratings over operating free-air temperature range (unless otherwise noted)†

Supply voltage (see Note 1): V_{CC+}	22 V
V_{CC-}	-22 V
Input voltage, either input (see Notes 1 and 2)	$V_{CC\pm}$
Input current (see Note 3)	± 10 mA
Duration of output short circuit (see Note 4)	Unlimited
Package thermal impedance, θ_{JA} (see Note 5): D package	97°C/W
P package	85°C/W
PS package	95°C/W
Lead temperature 1,6 mm (1/16 inch) from case for 10 seconds	260°C
Storage temperature range, T_{stg}	-65°C to 150°C

† Stresses beyond those listed under "absolute maximum ratings" may cause permanent damage to the device. These are stress ratings only, and functional operation of the device at these or any other conditions beyond those indicated under "recommended operating conditions" is not implied. Exposure to absolute-maximum-rated conditions for extended periods may affect device reliability.

- NOTES:
1. All voltage values, except differential voltages, are with respect to the midpoint between V_{CC+} and V_{CC-} .
 2. The magnitude of the input voltage must never exceed the magnitude of the supply voltage.
 3. Excessive input current will flow if a differential input voltage in excess of approximately 0.6 V is applied between the inputs, unless some limiting resistance is used.
 4. The output may be shorted to ground or either power supply. Temperature and/or supply voltages must be limited to ensure the maximum dissipation rating is not exceeded.
 5. The package thermal impedance is calculated in accordance with JESD 51-7.



POST OFFICE BOX 655303 • DALLAS, TEXAS 75265

NE5532, NE5532A DUAL LOW-NOISE OPERATIONAL AMPLIFIERS

SLOS075G – NOVEMBER 1979 – REVISED JUNE 2002

recommended operating conditions

	MIN	MAX	UNIT
V _{CC+} Supply voltage	5	15	V
V _{CC-} Supply voltage	-5	-15	V
T _A Operating free-air temperature range	0	70	°C

electrical characteristics, V_{CC±} = +15 V, T_A = 25°C (unless otherwise noted)

PARAMETER		TEST CONDITION†		MIN	TYP	MAX	UNIT
V _{IO}	Input offset voltage	V _O = 0	T _A = 25°C		0.5	4	mV
			T _A = 0°C to 70°C			5	
I _{IO}	Input offset current		T _A = 25°C		10	150	nA
			T _A = 0°C to 70°C			200	
I _{IB}	Input bias current		T _A = 25°C		200	800	nA
			T _A = 0°C to 70°C			1000	
V _{ICR}	Common-mode input-voltage range			±12	±13		V
V _{OPP}	Maximum peak-to-peak output-voltage swing	R _L ≥ 600 Ω	V _{CC±} = ±15 V		24	26	V
			V _{CC±} = ±18 V		30	32	
A _{VD}	Large-signal differential-voltage amplification	R _L ≥ 600 Ω, V _O = ±10 V	T _A = 25°C		15	50	V/mV
			T _A = 0°C to 70°C		10		
		R _L ≥ 2 kΩ, V _O = ±10 V	T _A = 25°C		25	100	
			T _A = 0°C to 70°C		15		
A _{vd}	Small-signal differential-voltage amplification	f = 10 kHz			2.2		V/mV
B _{OM}	Maximum-output-swing bandwidth	R _L = 600 Ω	V _O = ±10 V		140		kHz
			V _{CC±} = ±18 V, V _O = ±14 V		100		
B ₁	Unity-gain bandwidth	R _L = 600 Ω, C _L = 100 pF			10		MHz
r _i	Input resistance			30	300		kΩ
z _o	Output impedance	A _{VD} = 30 dB, R _L = 600 Ω, f = 10 kHz			0.3		Ω
CMRR	Common-mode rejection ratio	V _{IC} = V _{ICR} min		70	100		dB
k _{SVR}	Supply-voltage rejection ratio (ΔV _{CC±} /ΔV _{IO})	V _{CC±} = ±9 V to ±15 V, V _O = 0		80	100		dB
I _{OS}	Output short-circuit current			10	38	60	mA
I _{CC}	Total supply current	V _O = 0, No load			8	16	mA
	Crosstalk attenuation (V _{O1} /V _{O2})	V _{O1} = 10 V peak, f = 1 kHz			110		dB

† All characteristics are measured under open-loop conditions with zero common-mode input voltage, unless otherwise specified.

operating characteristics, V_{CC±} = ±15 V, T_A = 25°C

PARAMETER	TEST CONDITIONS	NE5532			NE5532A			UNIT
		MIN	TYP	MAX	MIN	TYP	MAX	
SR	Slew rate at unity gain		9			9		V/μs
	Overshoot factor	V _I = 100 mV, R _L = 600 Ω,	A _{VD} = 1, C _L = 100 pF	10%		10%		
V _n	Equivalent input noise voltage	f = 30 Hz		8		8	10	nV/√Hz
		f = 1 kHz		5		5	6	
I _n	Equivalent input noise current	f = 30 Hz		2.7		2.7		pA/√Hz
		f = 1 kHz		0.7		0.7		



IMPORTANT NOTICE

Texas Instruments Incorporated and its subsidiaries (TI) reserve the right to make corrections, modifications, enhancements, improvements, and other changes to its products and services at any time and to discontinue any product or service without notice. Customers should obtain the latest relevant information before placing orders and should verify that such information is current and complete. All products are sold subject to TI's terms and conditions of sale supplied at the time of order acknowledgment.

TI warrants performance of its hardware products to the specifications applicable at the time of sale in accordance with TI's standard warranty. Testing and other quality control techniques are used to the extent TI deems necessary to support this warranty. Except where mandated by government requirements, testing of all parameters of each product is not necessarily performed.

TI assumes no liability for applications assistance or customer product design. Customers are responsible for their products and applications using TI components. To minimize the risks associated with customer products and applications, customers should provide adequate design and operating safeguards.

TI does not warrant or represent that any license, either express or implied, is granted under any TI patent right, copyright, mask work right, or other TI intellectual property right relating to any combination, machine, or process in which TI products or services are used. Information published by TI regarding third-party products or services does not constitute a license from TI to use such products or services or a warranty or endorsement thereof. Use of such information may require a license from a third party under the patents or other intellectual property of the third party, or a license from TI under the patents or other intellectual property of TI.

Reproduction of information in TI data books or data sheets is permissible only if reproduction is without alteration and is accompanied by all associated warranties, conditions, limitations, and notices. Reproduction of this information with alteration is an unfair and deceptive business practice. TI is not responsible or liable for such altered documentation.

Resale of TI products or services with statements different from or beyond the parameters stated by TI for that product or service voids all express and any implied warranties for the associated TI product or service and is an unfair and deceptive business practice. TI is not responsible or liable for any such statements.

Mailing Address:

Texas Instruments
Post Office Box 655303
Dallas, Texas 75265