

TA7612AP

LED Driver

The TA7612AP is designed for 10 LED level meter driver.

Features

- 10 LED's bar display driver.
- Linear scale display.
- Continuous 10 LED display.
- By choosing a series connection of IC, can display more than 10 LED.

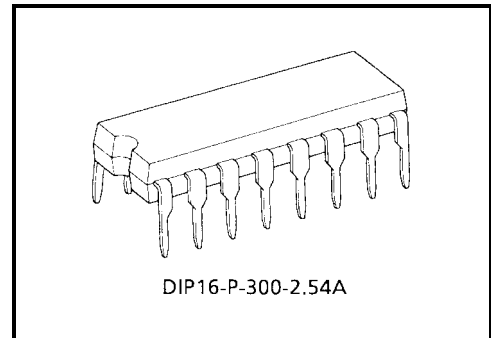

Weight: 1.00 g (typ.)

Block Diagram (Note 1)

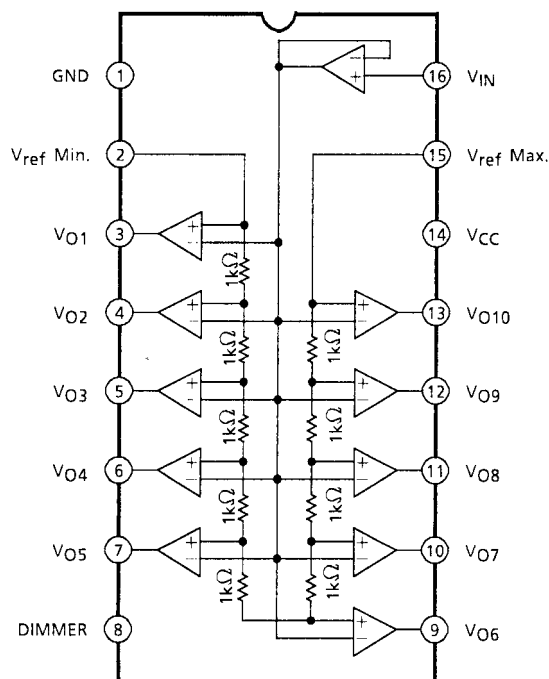

Note 1: ($V_{ref\ max} (= PIN\ 15) = 3.6\ V$)

2 Pin Connection	Display	Condition
Terminated ground	Light on No.1 LED	$V_{IN} = 0\sim 0.4\ V$ (typ.)
	Lighted all LED	$V_{IN} \geq 3.6\ V$ (typ.)
Terminated 1 kΩ between ground	Without lighted No.1 LED	$V_{IN} = 0\sim 0.36\ V$ (typ.)
	Light on No.1 LED	$V_{IN} \geq 0.36\ V$ (typ.)

P_D Calculation At 10 LEDs

$$P_D = V_{CC} \times I_{CC1} + V_{OL} \times I_O \times 10 \text{ (W)}$$

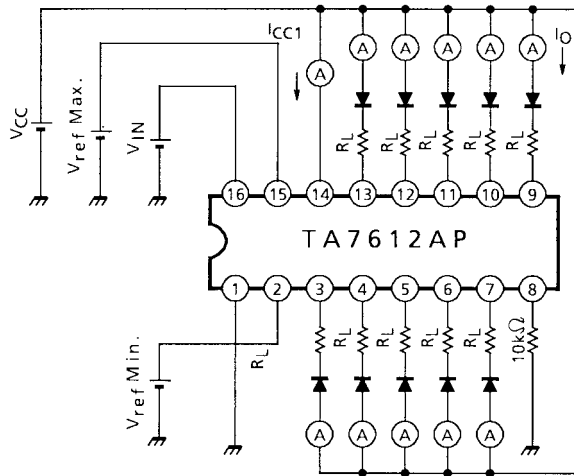

Note: V_{OL} is: $V_{OL} = V_{CC} - V_F \text{ (LED)} - R_L \times I_O$ (When each output is "ON".)

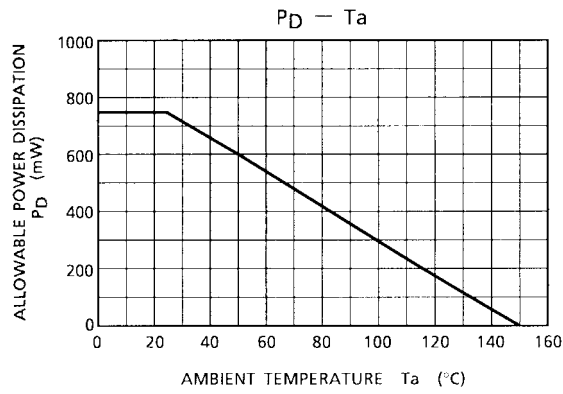

Functional Description

Block diagram

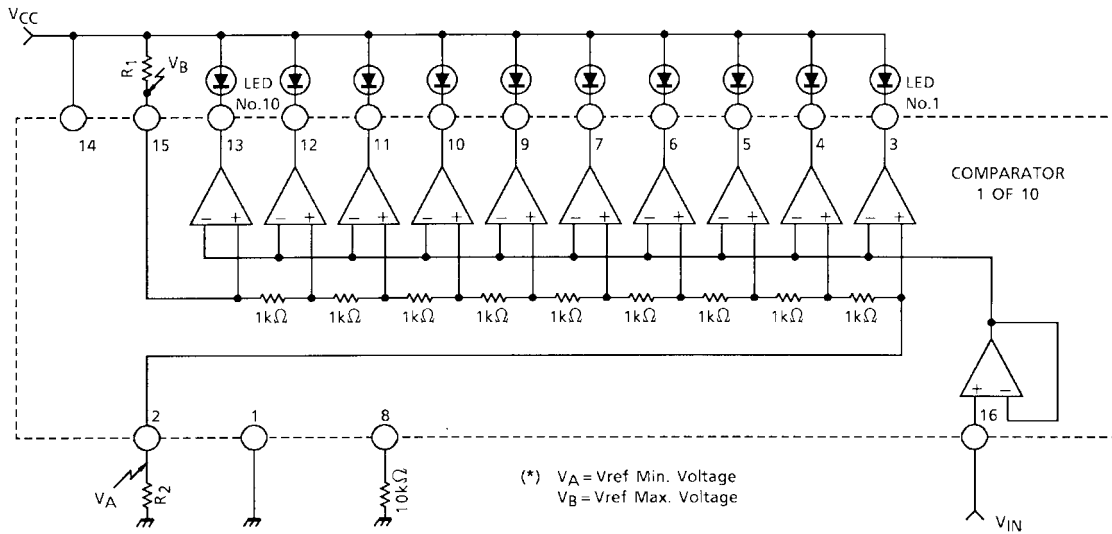

The above simplified TA7612AP Block Diagram is to give the general idea of the circuit's operation.

- (1) General operation
 If V_{IN} Voltage greater than the first threshold but less than the second threshold is applied "No.1" LED is lighted, if the input voltage is between the second and the third threshold, then 'No.1 and No.2' LED are in operation and so on.
- (2) Adding R_1 and R_2 operation
 These resistors are to give the reference voltage of 10 comparators.
 And then above $V_B - V_A$ is to give the Input Voltage sensitivity of this device.
 R_1 and R_2 will be calculated as follows.

$$\frac{R_2}{R_1 + R_2 + 9\Omega} \times V_{CC} = V_A \dots\dots\dots (1)$$

$$\frac{R_2 + 9\Omega}{R_1 + R_2 + 9\Omega} \times V_{CC} = V_B \dots\dots\dots (2)$$

From (1) and (2)

$$R_1 = \frac{9 (V_{CC} - V_B)}{V_B - V_A} \text{ (k}\Omega\text{)} \dots\dots\dots (3)$$

$$R_2 = \frac{9V_A}{V_B - V_A} \text{ (k}\Omega\text{)} \dots\dots\dots (4)$$

How to adjust the dimmer

Toshiba recommends that the value of the resistor at pin 8 be set to 10 kΩ (up to 100 kΩ).
 If the value of the resistor is set lower, the current that flows through each $VO_1 \sim 10$ and the power dissipation will increase. Thus, when setting the value of the resistor, care must be taken with the relationship between the power dissipation (max) and the current that is required to drive LEDs.

Maximum Ratings (Ta = 25°C)

Characteristics	Symbol	Rating	Unit
Supply voltage	V _{CC}	20	V
Power dissipation (Note 2)	P _D	750	mW
Operating temperature	T _{opr}	-30~75	°C
Storage temperature	T _{stg}	-55~125	°C

Note 2: Derated above Ta = 25°C in the proportion of 6 mW/°C.

Electrical Characteristics (Ta = 25°C, V_{CC} = 12 V)

Characteristics	Symbol	Test Circuit	Test Condition	Min	Typ.	Max	Unit
Supply voltage	V _{CC}	—	—	6	12	15	V
Supply current (1)	I _{CC1}	—	V _{ref} = 4 V, V _{IN} = 0 V	—	15	20	mA
Supply current (2)	I _{CC2}	—	V _{ref} = 4 V, V _{IN} = 4.1 V I _O = 10 mA × 10	—	150	160	mA
Input bias current	R _{TOT}	—	—	7	9	11	kΩ
Internal resistance	I _{IN}	—	V _{IN} = GND	—	-0.25	-1	μA
Input voltage range	V _{IN}	—	—	0	—	8	V
Output offset voltage	V _{OFF}	—	V _{ref} = 4 V	-40	—	40	mV
Output voltage (high level)	V _{OH}	—	V _{ref} = 4 V, V _{IN} = GND R _L = 1.5 kΩ	11.9	11.93	—	V
Output voltage (low level)	V _{OL}	—	V _{ref} = 4 V, V _{IN} = 4.10 V R _L = 1.5 kΩ	—	0.6	1.0	V
Output current	I _O	—	V _{ref} = 4 V, V _{IN} = 4.10 V	—	7	12	mA
Leak current	I _{IL}	—	V _{IN} = 4 V V _{ref Max} = 0 V, V _{ref Min} = 0 V	—	—	15	μA

Application Circuit

10 LEDs applications

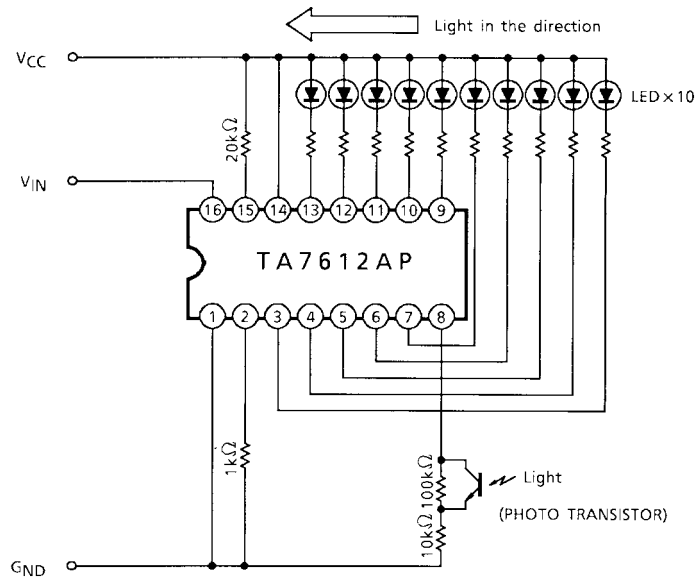

20 LEDs applications

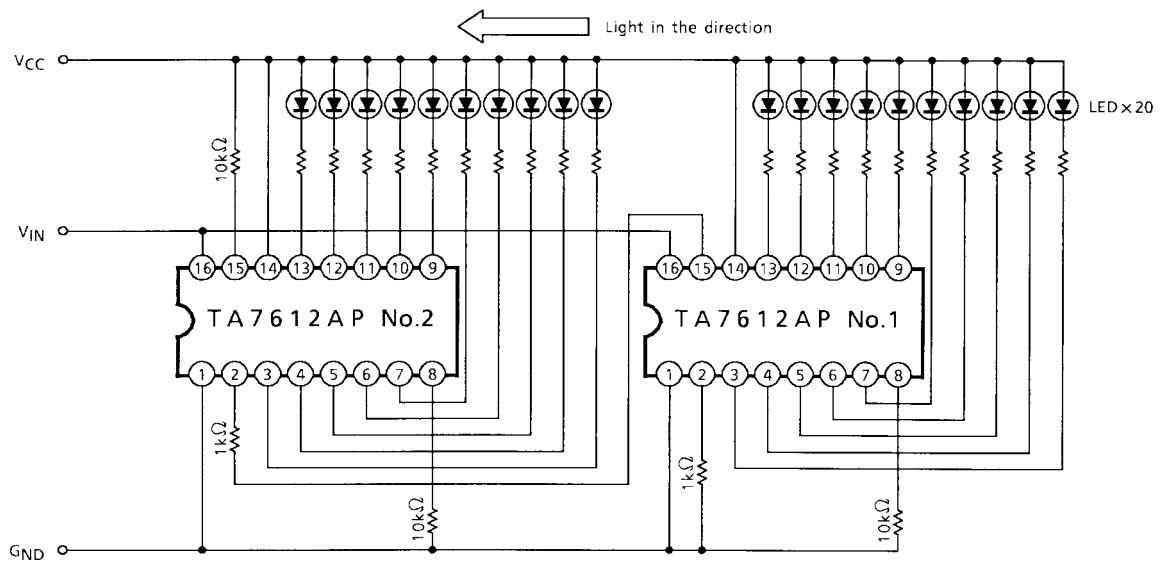

Package Dimensions

DIP16-P-300-2.54A

Unit : mm

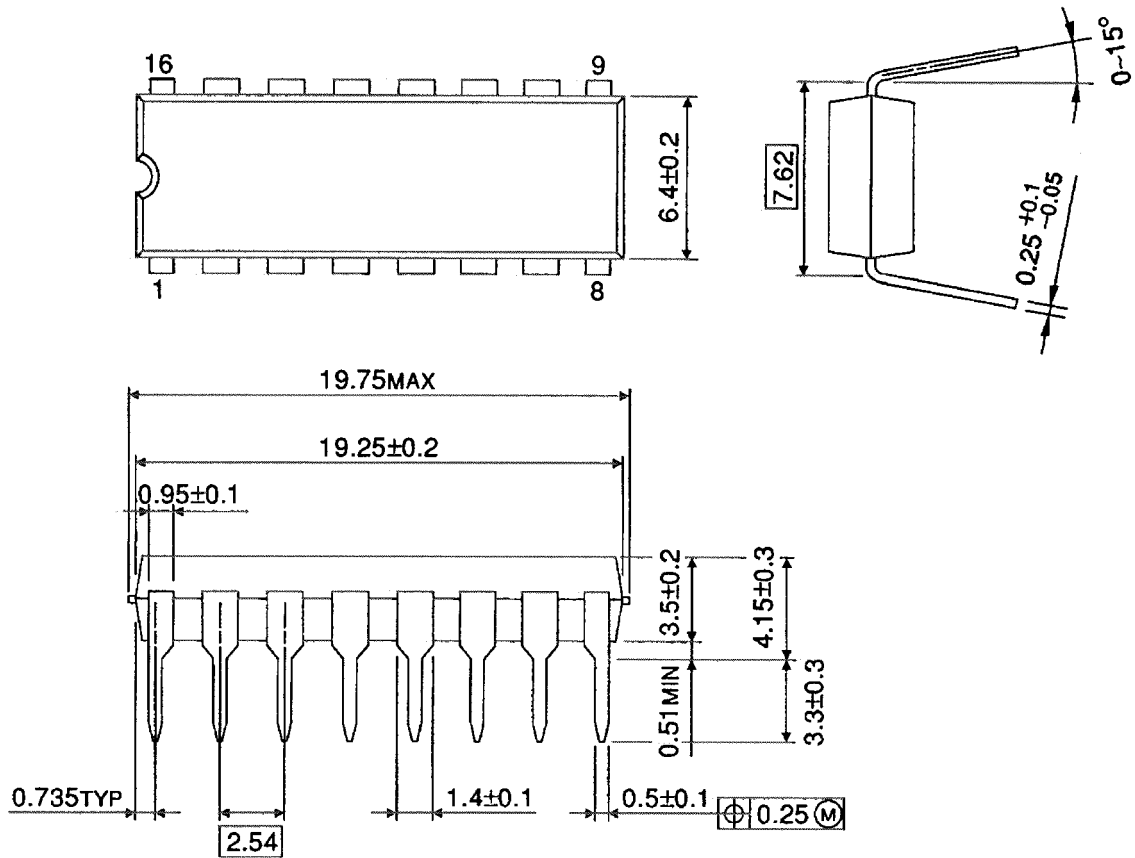

Weight: 1.00 g (typ.)

RESTRICTIONS ON PRODUCT USE

000707EBA

- TOSHIBA is continually working to improve the quality and reliability of its products. Nevertheless, semiconductor devices in general can malfunction or fail due to their inherent electrical sensitivity and vulnerability to physical stress. It is the responsibility of the buyer, when utilizing TOSHIBA products, to comply with the standards of safety in making a safe design for the entire system, and to avoid situations in which a malfunction or failure of such TOSHIBA products could cause loss of human life, bodily injury or damage to property.
In developing your designs, please ensure that TOSHIBA products are used within specified operating ranges as set forth in the most recent TOSHIBA products specifications. Also, please keep in mind the precautions and conditions set forth in the "Handling Guide for Semiconductor Devices," or "TOSHIBA Semiconductor Reliability Handbook" etc..
- The TOSHIBA products listed in this document are intended for usage in general electronics applications (computer, personal equipment, office equipment, measuring equipment, industrial robotics, domestic appliances, etc.). These TOSHIBA products are neither intended nor warranted for usage in equipment that requires extraordinarily high quality and/or reliability or a malfunction or failure of which may cause loss of human life or bodily injury ("Unintended Usage"). Unintended Usage include atomic energy control instruments, airplane or spaceship instruments, transportation instruments, traffic signal instruments, combustion control instruments, medical instruments, all types of safety devices, etc.. Unintended Usage of TOSHIBA products listed in this document shall be made at the customer's own risk.
- The products described in this document are subject to the foreign exchange and foreign trade laws.
- The information contained herein is presented only as a guide for the applications of our products. No responsibility is assumed by TOSHIBA CORPORATION for any infringements of intellectual property or other rights of the third parties which may result from its use. No license is granted by implication or otherwise under any intellectual property or other rights of TOSHIBA CORPORATION or others.
- The information contained herein is subject to change without notice.